

QUALTECH



INCLINED VERTICAL CHEESE PRESS

CUSTOMIZABLE AND EASY TO OPERATE

Our vertical cheese press is customizable according to your needs. It has 2 to 12 heads. With its simple and efficient construction, the press is easy to move and operate

- > Easily washable 304 stainless steel sanitary construction
- > Adjustable pressure regulator to modulate the pressing force
- > Independent control of each cylinder via manual valves with stainless steel handles
- > A cylinder extension rod provided to allow for partial stacking
- > Whey recovery pan with central drain and a tri-clamp ferrule output connection
- > Designed for rectangular molds 11" x 14" (20 or 40 pounds)
- > 11 molds 11" x 14" 20 pounds per stack
- > Possibility of pressing round molds from 6" to 12" in diameter
- > Combination of molds of different formats, round and / or rectangular, possible



24/7
EMERGENCY
SERVICE
1-888-339-3801

INFO@QUALTECH.CA
QUALTECH.CA

SPECIFICATIONS

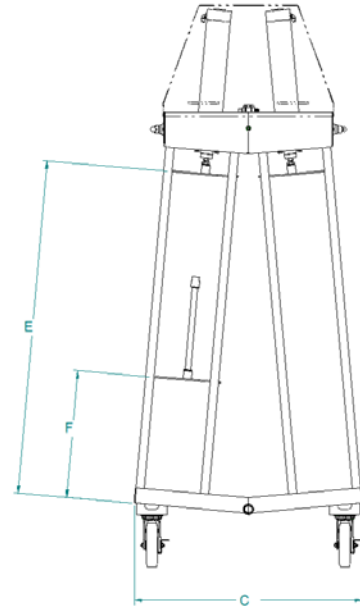
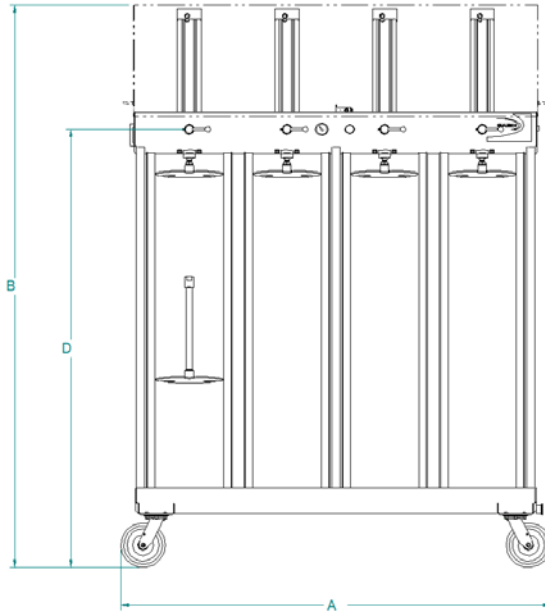

MODEL	CAPACITY [Heads]	A [in]	B [in]	C [in]	D [in]	E [in]	F [in]
PFV01-02	2	39	88 3/4	28	55 1/2	50	13
PFV01-04	4	38 1/4	98 3/4	41	76 1/2	60	23
PFV01-06	6	59 1/2	100 3/4	41	78 1/2	60	23
PFV01-08	8	77	100 3/4	41	78 1/2	60	23
PFV01-10	10	94 1/2	101	41	78 3/4	60	23
PFV01-12	12	112	101	41	78 3/4	60	23

PFV01	Configuration choice	02	04	06	08	10	12		Code	(a)
Number of pressing heads		2	4	6	8	10	12			
Type of molds	Rectangular 20 to 40 pounds	●	●	●	●	●	●		RC	(b)
	Round 6 to 12"	□	□	□	□	□	□		RN	
	Multi-format ¹	□	□	□	□	□	□		MT	
Cylinder cover	None	●	●	●	●	●	●		0	(c)
	With	□	□	□	□	□	□		C	
Material in contact with the product	AISI 304	●	●	●	●	●	●		4	(d)
	AISI 316	□	□	□	□	□	□		6	

● : by default on basic model | □ : available as an option

¹ Combination of molds of different formats, round and / or rectangular

PFV01 - (a) 08 (b) RC (c) C (d) 4